

INSTALLATION INSTRUCTIONS	INSTRUCTIONS POUR L'INSTALLATION	MONTAGE-ANLEITUNG	MONTAGE HANDLEIDING
Accessory	Accessoire	Zubehör	Accessoire
SUN BLINDS	PARE-SOLEIL	SONNENBLENDEN	ZONNEKLEPPEN
ISTRUZIONI DI MONTAGGIO	INSTRUCCIONES DE INSTALACIÓN	INSTRUÇÕES PARA A INSTALAÇÃO	MONTERINGS-ANVISNINGAR
Accessorio	Accesorio	Accessório	Tillbehör
PARASOLE	PERSIANAS	PROTETORES CONTRA O SOL	MARKISER
Issue Date Date de parution Veröffentlichungsdatum Uitgiftedatum	Data di pubblicazione Fecha de edición Data de emissão Utgivningsdatum	Application Utilisation Anwendung Toepassing	Impiego Aplicación Aplicação Används till
	06/2005		2001 CIVIC 5DR

**PARTS LIST • LISTE DE PIÈCES • TEILELISTE • ONDERDELENLIJST
ELENCO DEI COMPONENTI • LISTA DE PIEZAS • LISTA DE PEÇAS • MATERIAL**

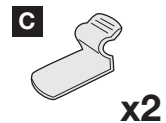
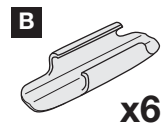
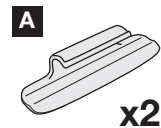
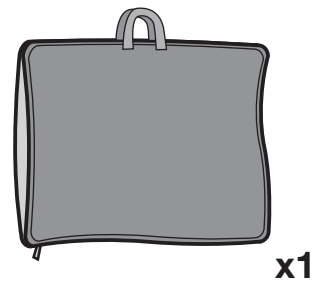
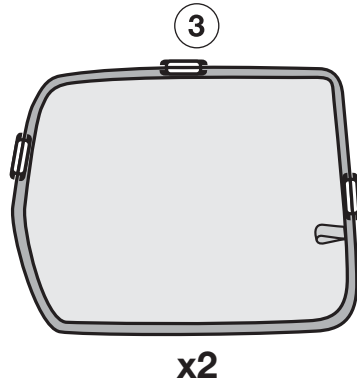
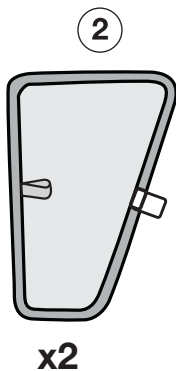
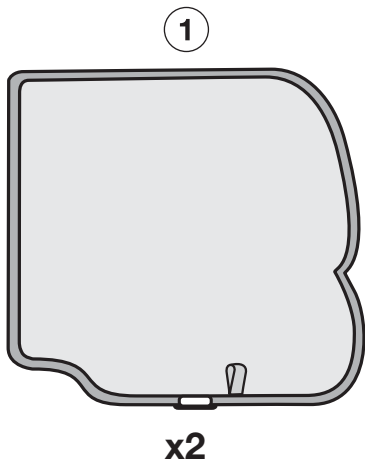
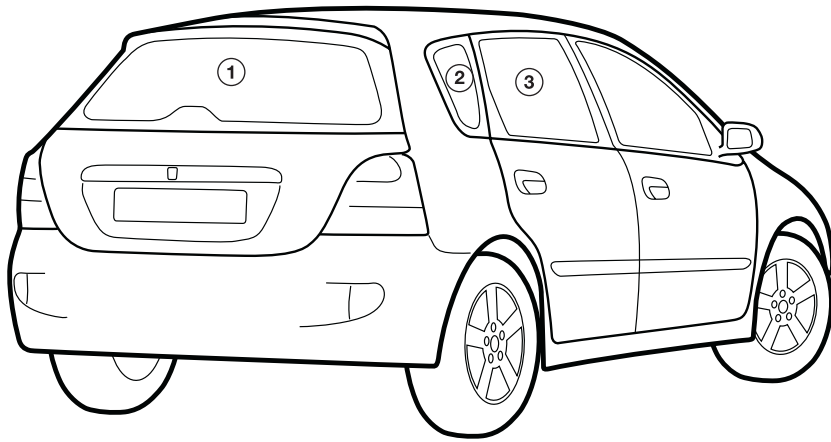

HONDA

GENUINE ACCESSORIES

WARNING

- Read these fitting instructions carefully before you start the installation.
- On installation care must be taken not to scratch any paintwork with clips.
- Rear passenger windows must be closed whilst the sun blinds are fitted and the vehicle is in motion.

ATTENTION

- Lisez attentivement ces instructions de montage avant de commencer l'installation.
- Lors de l'installation, veillez à ne pas griffer la peinture avec des attaches.
- La vitre côté passager arrière doit être fermée pendant la fixation des pare-soleil, quand le véhicule est en mouvement.

WARNUNG

- Lesen Sie diese Montageanleitungen sorgfältig, bevor Sie mit der Montage beginnen.
- Bei der Montage muss darauf geachtet werden, dass der Lack nicht mit den Klemmen zerkratzt wird.
- Heckfenster müssen geschlossen werden, während die Sonnenblenden montiert werden, und sich das Fahrzeug bewegt.

WAARSCHUWING

- Lees deze montagehandleiding aandachtig alvorens met de montage te beginnen.
- Zorg ervoor dat u bij de montage de lak niet schendt met de clips.
- De vensters van de achterportieren moeten dicht blijven wanneer er zonnecleppen gemonteerd zijn en het voertuig in beweging is.

ATTENZIONE

- Leggere attentamente le presenti istruzioni di montaggio prima di iniziare l'installazione.
- Nel corso dell'installazione si avrà cura di non graffiare la vernice con le clip.
- I finestrini posteriori rimarranno chiusi se sono montati i parasole ed il veicolo è in movimento.

ATENCIÓN

- Lea atentamente estas instrucciones de colocación antes de comenzar la instalación.
- Durante la instalación se debe tener cuidado de no rayar la pintura con los clips.
- Las ventanas traseras se deben cerrar mientras se ajustan las persianas y el vehículo está en movimiento.

AVISO

- Leia com atenção estas instruções de colocação antes de você iniciar a instalação.
- Tenha cuidado ao instalar para não riscar nenhuma pintura com os cliques.
- As janelas traseiras do passageiro deverá ser fechada enquanto os protetores contra o sol estiverem colocados e o veículo estiver em movimento.

VARNING

- Läs dessa monteringsanvisningar noga innan du börjar montera.
- Vid installationen måste du vara försiktig så att lacken inte repas av clipsen.
- De bakre passagerarfönstren måste vara stängda när markiserna sätts fast och fordonet är i rörelse.

- 1**
- TAILGATE OPEN
 - HAYON OUVERT
 - HECKKLAPPE GEÖFFNET
 - ACHTERKLEP OPEN
 - PORTABAGAGLI APERTO
 - PUERTA TRASERA ABIERTA
 - ABERTURA DA PORTA TRASEIRA
 - BAKLUCKAN ÖPPEN

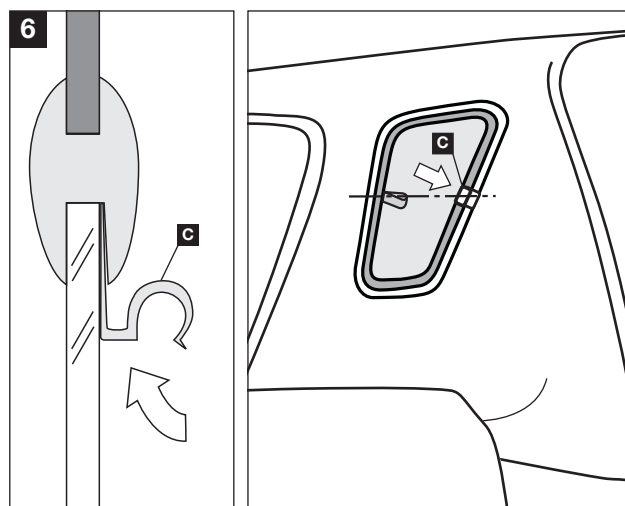
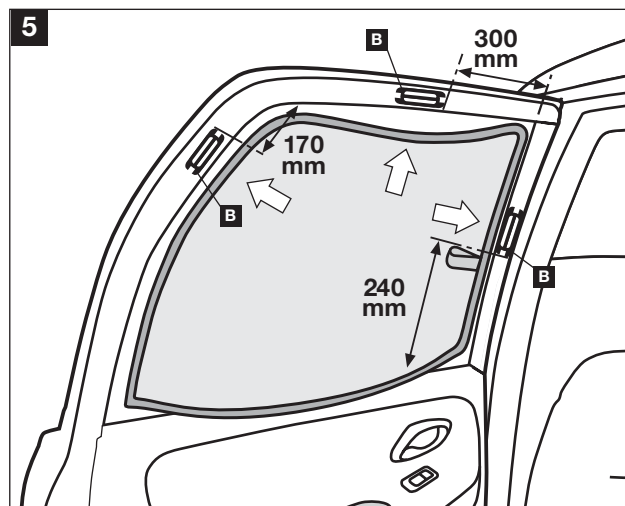
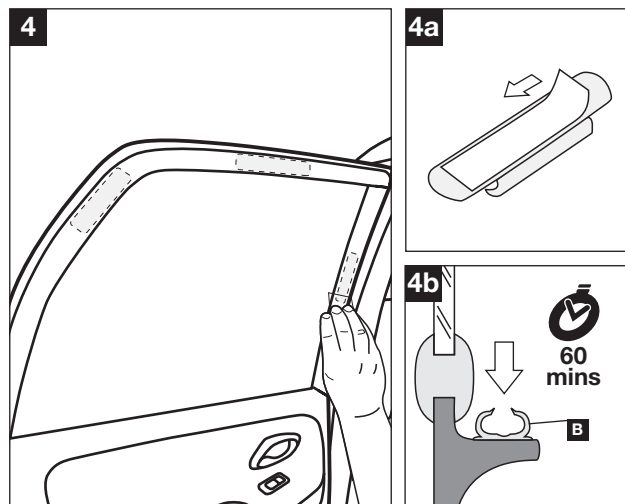
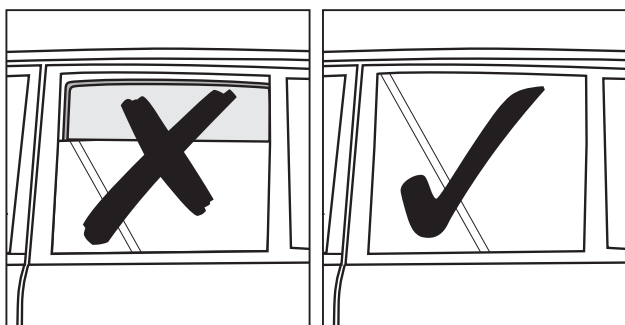
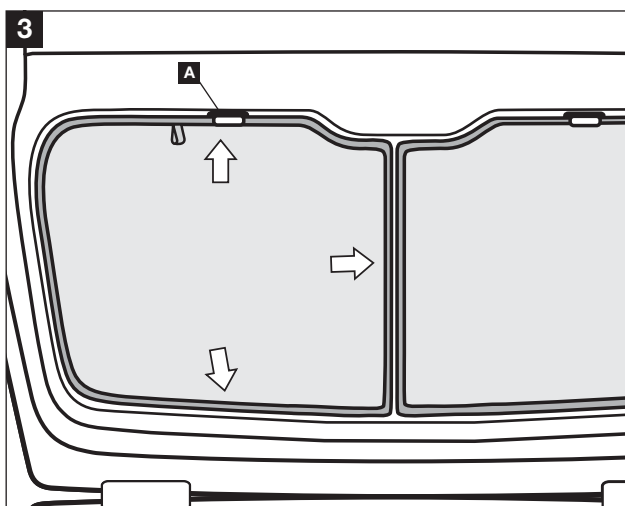
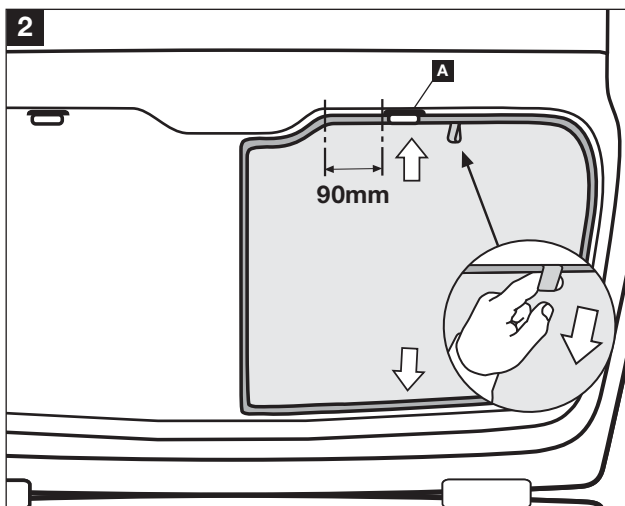
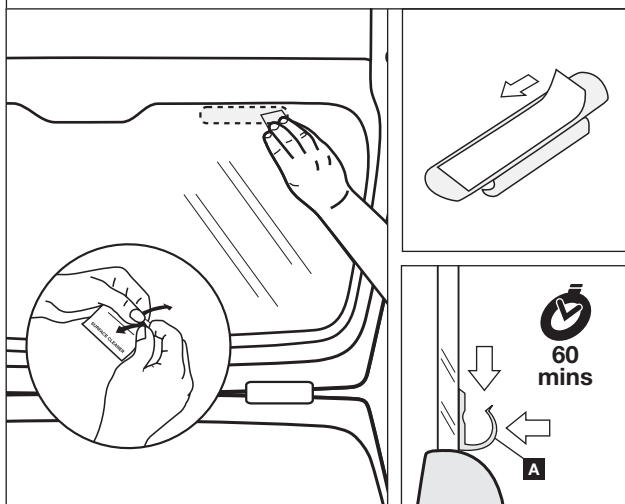

NOTE

Each clip must be mounted on the inner edge of the metal frame closest to the rubber. Ensure the opening of each clip faces outwards, see diagram 4b.

NOTE

Chaque attache doit être montée sur le rebord intérieur du châssis en métal, le plus près possible du caoutchouc. Veillez à ce que l'ouverture de chaque attache soit tournée vers l'extérieur (voir le schéma 4b).

ANMERKUNG

Jede Klemme muss auf der Innenseite des Metallrahmens, in größtmöglicher Nähe zum Gummi, montiert werden. Sorgen Sie dafür, dass die Öffnung jeder Klemme nach außen zeigt, gemäß Diagramm 4b.

OPMERKING

Elke clip moet gemonteerd worden op de binnenrand van het metalen frame het dichtst bij het rubber. Zorg ervoor dat de opening van elke clip naar buiten wijst, zie diagram 4b.

NOTA

Ogni clip va montata sul bordo interno del telaio in metallo vicino al gommino. Verificare l'apertura di ogni clip verso l'esterno, cfr. diagramma 4b.

NOTA

Cada clip se debe montar en el borde interno del bastidor de metal más cercano al caucho. Verifique que la abertura de cada clip esté hacia adelante, ver diagrama 4b.

NOTA

Cada clipe deverá ser montado na beirada interna do quadro de metal, o mais perto possível da borracha. Tenha a certeza de que a abertura de cada clipe se dirija para fora, veja o diagrama 4b.

OBS

Alla clips måste monteras på metallramens insida, närmast gummit. Se till att öppningen på alla clips är riktad utåt. Se diagram 4b.